



M+F | Solutions

# OPTIMIZED EFFICIENCY FOR FUEL HANDLING

Solutions for highest precision and reliability



# M+F TECHNOLOGIES: YOUR INNOVATIVE SOLUTION PROVIDER

Responding to your individual demands

As a solution provider, **M+F Technologies** provides you with its outstanding expertise in the handling of oil products. Our leading market position is underpinned by our long-standing know-how in loading processes in the oil industry and our continuous development work that benefits our customers around the world: We offer you complete system solutions based on our own technologies and state-of-the-art products, covering all your needs, from consulting and engineering to implementation and even including regular servicing.

As an experienced specialist, we take care of all tasks linked to the automation and management of tank farms, tank terminals and fuel supply systems. Our focus here is on loading systems for tank trucks, rail cars and ships, as well as on blending systems and fuel supply systems at airports.

- **Understanding of the industry:** proprietary products and pioneering technologies that reflect our profound know-how
- **Expertise:** tailored solutions reflecting the comprehensive understanding of the individual context
- **MID conformity:** measurement systems for all loading applications in the oil industry in accordance with the Measuring Instruments Directive

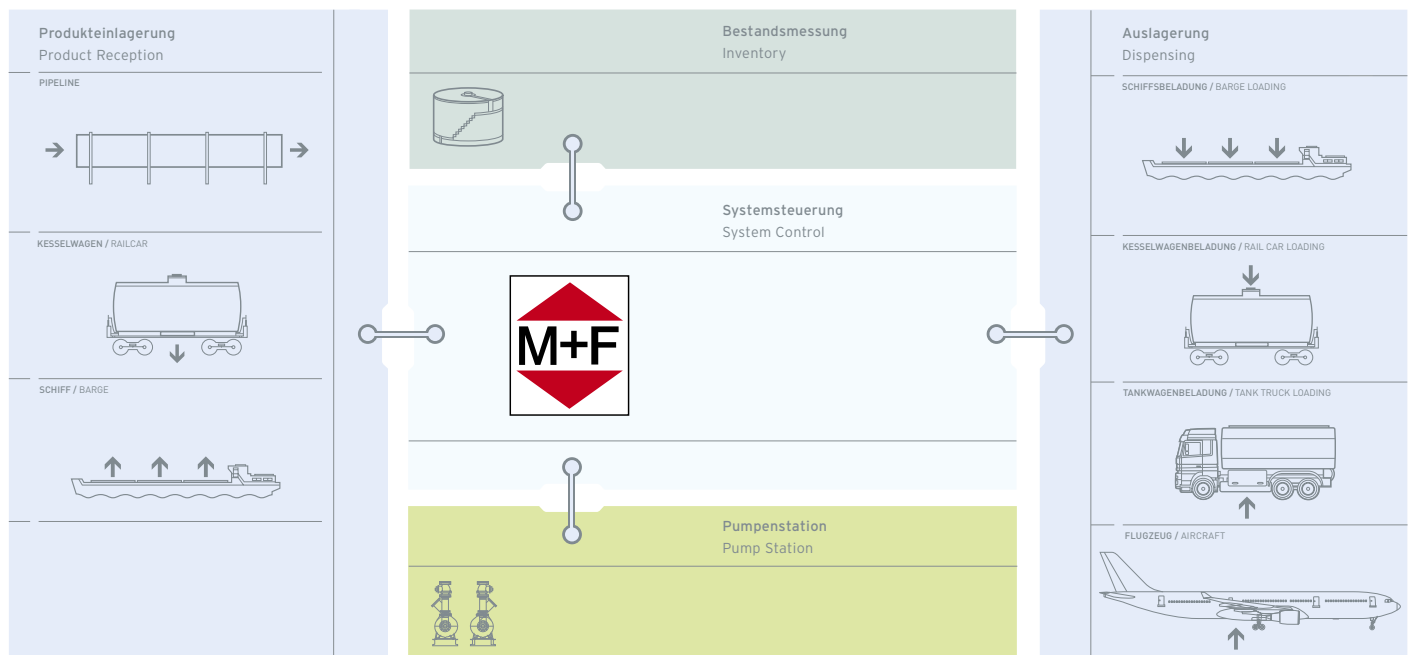

↑ Our services at a glance

# FUEL HANDLING IN TANK FARMS AND TERMINALS

We cover the full scope

We have supplied and developed top quality products for use in fuel supply systems for more than 30 years. Due to our high level of experience and technical competence, M+F systems are characterised by a high standard of quality and optimal functionality at a high technical level.

We provide modular structured partial and complete solutions using their own products and those from other leading manufacturers.

## SYSTEM SOLUTIONS FOR:

- Product reception
- Truck loading
- Truck identification
- Additive injection
- Pump systems

- Rail Car loading
- Ship loading
- Terminal automation

→ **Comprehensive support:** consulting, engineering and project realization from a single source

## COMPLETE SOLUTIONS FOR:

Modular structured and complete solutions for loading terminals:

- Measurement and control of received products
- Vapor recovery
- Measurement of storage quantities for product inventory
- Loading technology, volume measurement and connection to automation system

- Access control and identification systems
- Special loading technology for railcars and barges
- Systems for inline and batch blending
- Pump units and control systems for fuel supply
- Control of all product reception, inventory and product delivery

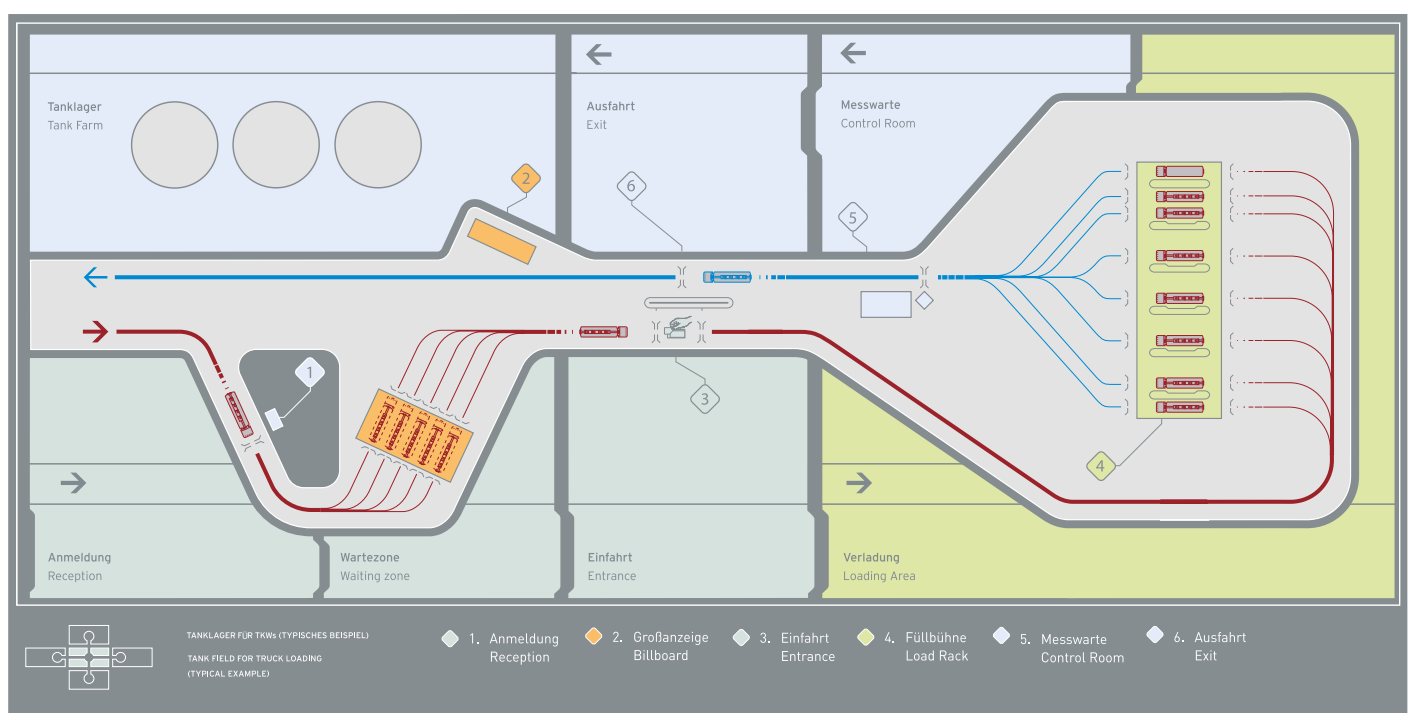



M+F | Solutions

# SEAMLESS OPERATION IN LOADING TERMINALS

Solutions for highest precision and reliability

## PRODUCT RECEPTION

Loading the exact quantity of the supplied fuel is an important part of the inventory control process. A friction-free process and high level of precision and reliability is required for input measurement.

Our products provide this safety and integrate the fuelling in the complete logistics in the tank farm.

- Measurement systems
- Unloading technology
- Control technology

→ **In-house skid manufacturing:** offers highest quality control and full testing capabilities

→ **Enabling FAT:** under real operating conditions

## INVENTORY CONTROL

Inventory control of the fuel products in the tank farm must be carried out continuously. In **M+F Technologies** systems, the ideal tank level measurement system is used depending on the requirements of the tank farm and integrated seamlessly into the automation system.

Products:

- Level gauging
  - \_ Servo
  - \_ Radar
- Tank fittings
- Tank field control

→ **Seamless integration:** level gauging equipment into COTAS Terminal Automation Systems

## PUMP SYSTEMS

For optimal product movement even at peak times, tank farms require a carefully planned pump station, which **M+F** designs and manufactures in full consideration of the specific hydraulic requirements. We provide both the design and the complete delivery of the required pump units including their control systems.

Products:

- Pump skids
- Control systems

→ **Multi-stage-design:** with frequency control system

→ **Tailored solutions:** perfectly fit the hydraulic conditions of the existing pipe system



# TRUCK LOADING TERMINALS: INTEGRATED EFFICIENCY

We offer from single components to complete solutions

The cost-effectiveness of a tank farm depends on the optimal functionality of the loading system. This places high demands on measuring precision, operating safety, ease of operation and system availability. **M+F Technologies** offers consulting, engineering and the complete scope of design and manufacturing for complete loading systems, using latest technology such as the **MFX\_4** flow computers. Our scope of supply ranges from single components to complete solutions for truck loading.

Products:

- Compact metering skids CMS
- Batch controller MFX
- Additive injection systems CBU
- Bio fuel blending systems
- ID-Card reader/access control systems
- Loading control PLC

- **Profitability:** cost-efficient and secure handling of oil products
- **Integrated solution:** complete systems with highest accuracy in the recording and documentation of all product movements
- **Certification:** metrological approvals (MID, OIML, etc.)

## BATCH CONTROLLER/FLOW COMPUTER MFX\_4

**M+F Technologies** is a major supplier of batch controller/flow computer systems. With many major oil companies, the MFX series are the standard load controllers for custody transfer truck loading applications. More than 15.000 **MFX\_4** flow computers are in operation wherever highest reliability under OIML requirements is requested. The **MFX\_4** offers CANopen fieldbus communication in the field, TCP/IP for the outside world (i.e. SCADA and automa-

tion systems) and offers industry standard OPC technology for state-of-the-art communication.

The **MFX\_4** system can be installed on the gantry as well as in the control room. Its unique modular design allows high flexibility in its configuration and has OIML and international (Ex)-approvals.

↓ CMS: compact metering skid



↓ MFX\_4 terminal





# HANDLING SYSTEMS FOR MARINE TRANSPORTATION

For on-shore and off-shore applications

Regardless of the transportation means, we offer you all of the services that ensure the loading systems meet all requirements at the highest level - from the consulting stage to engineering and realization. The profitability of a tank farm heavily depends on the optimum functionality of the loading terminals. Our service range comprises individual components and skids as well as complete systems for the loading of tank trucks.

Loading systems for the marine transportation of oil are subject to particularly stringent regulations concerning health, safety, environmental and water protection. Our integrated solutions guarantee maximum efficiency even under these requirements. You can also make use of tailored solutions for the growing market of ship- and land-based bunker stations with integrated blending functionality.

- **Bunker blending skids:** for on-shore and off-shore applications
- **Broad product range:** modular, scalable and high-quality skids for the handling of oil products
- **Comprehensive support:** consulting, engineering and project realization from a single source

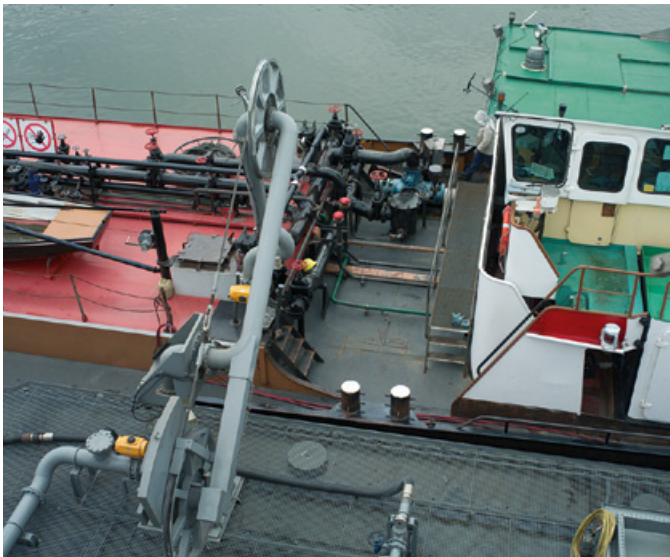

↑ Ship loading at riverside terminal

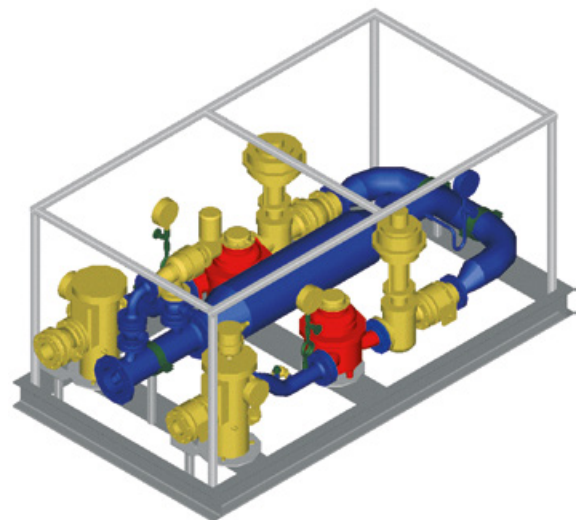

↑ Metering Skid: bunker blending

# RAIL CAR LOADING: HIGH LEVEL OF AUTOMATION

Superior quality for years

## ON-SPOT RAIL CAR LOADING

The on-spot technology is based on a sequential loading of a coupled train with a variety of products. Our on-spot filling pipe technology facilitates high-speed loading processes using hydraulic telescopic loading arms.



↑ On-spot rail car loading

We offer this technology with a long list of reference installations on an international scale.

- **Minimum personnel requirements:** high level of automation
- **Short loading times:** volume flows of up to 20,000 tonnes per day for multi-track operations
- **High level of flexibility:** multi-product loading using only a single loading arm
- **High degree of emission and environmental protection:** optimal vapour recovery technology, TA Luft certification (German Clean Air Act)

## SERIAL RAIL CAR LOADING

For rail car loading systems, M+F Technologies offers the full scope from consulting and detail engineering to the manufacturing of the loading systems and final commissioning.



↑ Serial rail car loading

Our rail car loading systems offer low cost of ownership. They are designed and field-proven for heavy-duty applications.

- **Engineering capability:** designed for fitting the individual requirements of the given installation
- **Complete range:** for the bulk fluid transfer of hazardous liquids, sizes from 2" to 6"
- **One source:** skid mounted metering systems for custody transfer, complete control systems and pump systems



M+F | Systems

## ACCESS CONTROL SYSTEMS

Operational safety and general security

In today's oil terminals, access control is a major issue when it comes to operational safety and general security issues. As a solution provider, **M+F Technologies** supplies access control technology that is specially designed for hazardous areas and offers latest technology by using proximity card reading, fingerprint recognition and fully automatic video nameplate recognition of trucks.

These systems seamlessly integrate into automation systems and are field proven in day-to-day rough operation in many tank farms and terminals.

- **Security:** combining the latest technologies for access control
- **Robustness:** designed for tough day-to-day operation
- **Understanding of the industry:** optimised for hazardous areas
- **Seamless integration:** easy integration into automation systems



↑ COTAS security modul at terminal entry

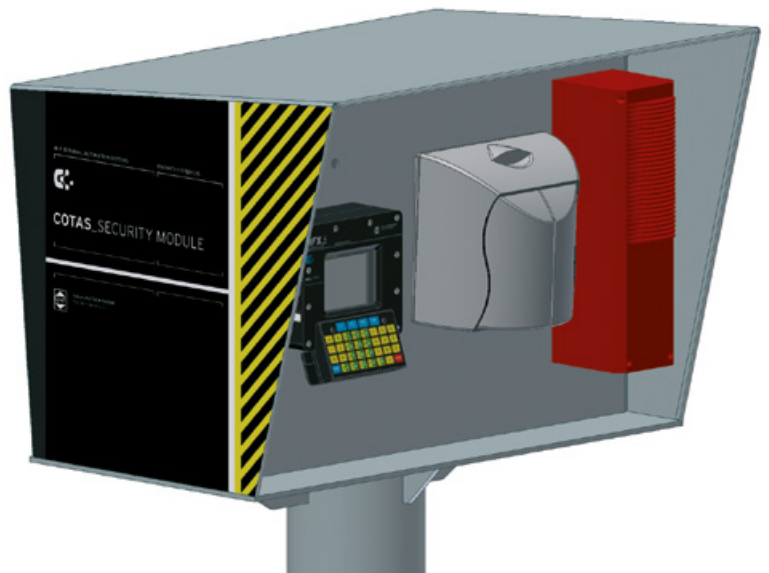

↑ COTAS security module



# COTAS: TRANSPARENCY IN THE TANK FARM

The software solution for greater flexibility

The terminal automation system **COTAS** is the complete solution for product transfer management and the controlling of all loading processes in the tank farm. The PC-based software coordinates the business processes, from storage and multi-client stock balancing to dispensing. **COTAS** is linked to all instrumentation in the field and controls the loading processes.

Thanks to its diverse and open interfaces, **COTAS** can integrate various measurement devices without difficulty and can itself be easily incorporated into higher-level ERP systems, such as SAP. Its highly flexible configuration means that **COTAS** can also be deployed rapidly in both small and large tank farms without any programming work.

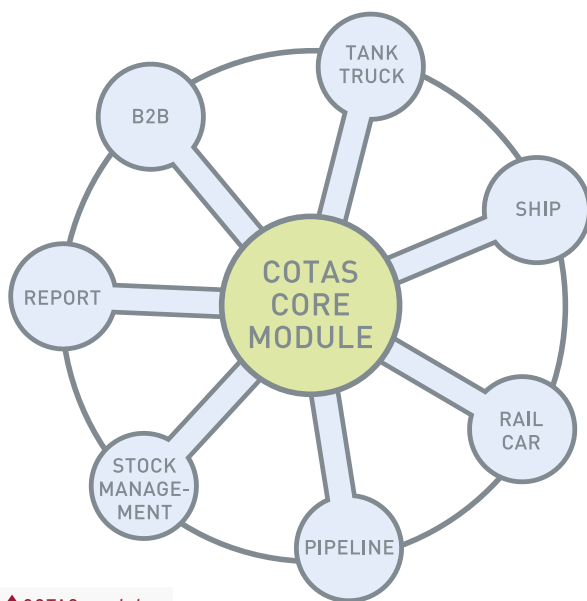

↑ COTAS modules

- **Modularity:** a broad selection of COTAS modules to satisfy varying requirements and configurable to suit the specific needs of the customer
- **Integrated solution:** a comprehensive overall understanding of all automation steps thanks to M+F flow computer technology
- **Short implementation times:** as an industry-specific software solution with rapid adjustability to suit customer requirements
- **Database independent:** open interfaces
- **EMCS integration:** fully automated integration in the European EMCS system for the movement of excise goods under duty suspension

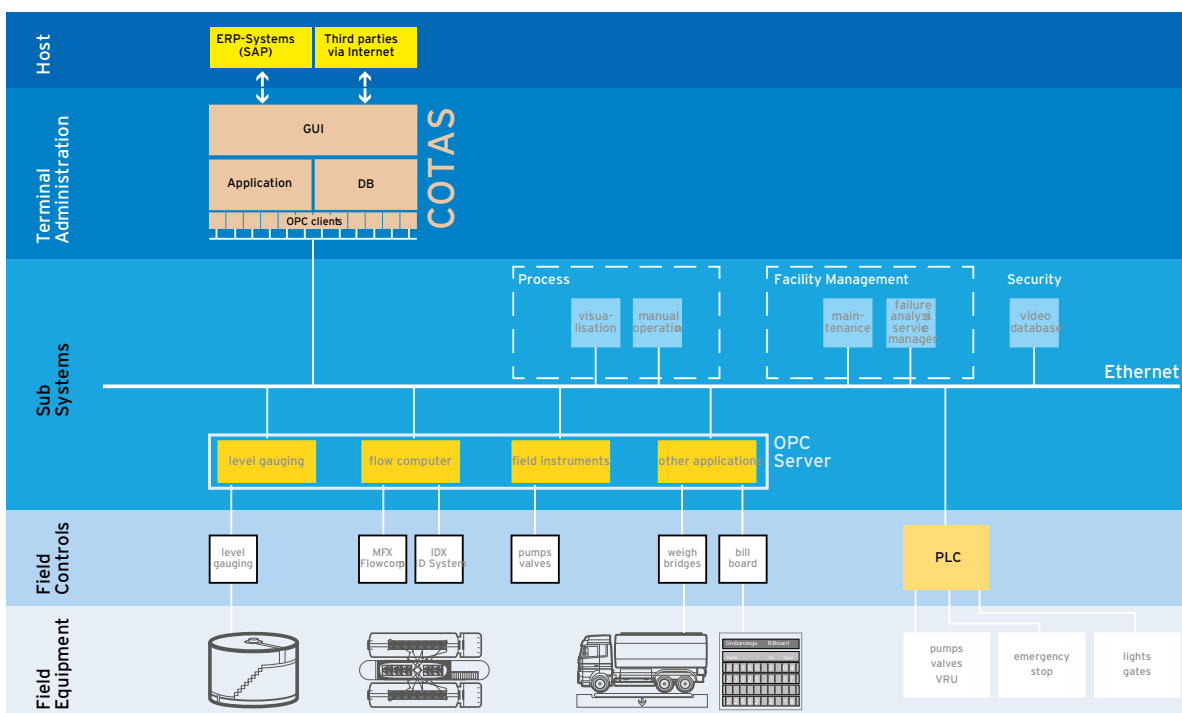

↑ OPC technology



M+F | Solutions

## SKID SYSTEMS: AS INDIVIDUAL AS YOUR SITE

Intelligent units made to measure

We provide you with a broad range of modular and scalable skids for the handling of oil products that are tailored to your respective needs. For example, compact metering skids (CMS) facilitate the custody transfer measurement of oil products. Furthermore, compact blending units (CBU) allow for the injection of additives and dyeing of the product stream.

Additionally, compact metering skids and blending units can be easily combined modularly to create complete multi-product loading stations. Our components of course meet all mandatory legal requirements, standards and guidelines, such as ATEX and MID.

- **Comprehensive support:** consulting, engineering and project realization from a single source
- **Broad product range:** modular, scalable and high-quality skids for the handling of oil products
- **Short installation times:** assembly and preliminary test at our factory under operating conditions
- **High level of flexibility:** greater transportability, easy combination and later expandability due to stable modular design



↑ CMS: compact metering skid



↑ MOBOTOP



## ADDITIVATION

When several oil companies jointly use the capacity of one tank farm, the injection of additives during the loading process is of growing importance.

We offer two different technologies for additive injection systems:

→ **CBU Single:** all additives controlled separately

→ **CBU Combined:** all additives controlled in one block

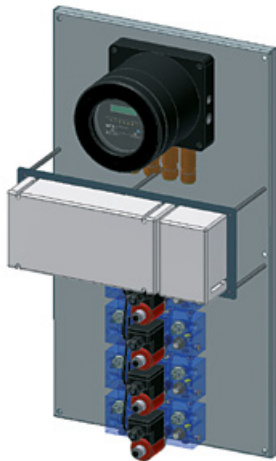

The **CBU Single** controls each additive separately, thus ensuring absolute separation of the different additives inside the unit. The CBU Single can optionally either be controlled by an external [i.e. the MFX\_4] or by its own additive controller.

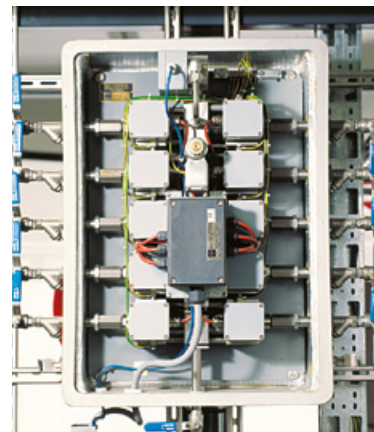

The **CBU Combined** offers up to 10 additives controlled in one single block and is controlled by an external additive controller [i.e. the MFX\_4].

## BIO FUEL BLENDING

More and more, bio fuel is used in addition to fossil fuels to reduce the dependence on its limited resources. We are offering field proven blending systems specifically designed for bio fuel applications.

There are several ways to blend bio fuels in loading terminals:

- Bio fuel blending during product reception [storage]
- Bio fuel blending in the header line for dispatching
- Bio fuel blending from tank to tank
- Bio fuel blending at loading position into truck, railcar or barge

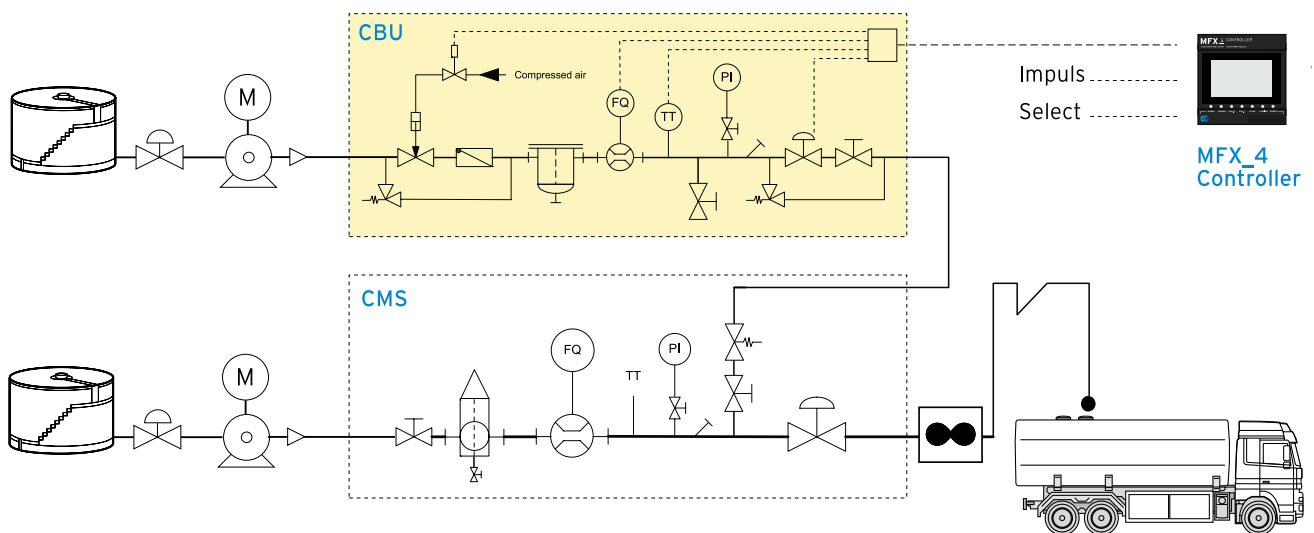





© M+F Technologies GmbH | Photo credits: © istock.com and own stock

Helbingtwiete 5  
22047 Hamburg | Germany

Phone +49 (0)40 72550 0  
Fax +49 (0)40 72550 111

info@m-f.tech  
www.m-f.tech